



FRONT Screen

Design by ARS

The FRONT SCREENS share the same versatility and performance as our other screens.

Their installation on the desk is just as simple as it is in the case of our other CONNECT screens. Place the screen on the already mounted base on the desk and enjoy a quiet space.

www.askiafurniture.ro

ASKIA



DAILY MAINTENANCE

Use a damp cloth to clean the entire surface of the divider. Use a microfiber cloth when dry dusting. Use a light touch and do not rub the cloth forcibly over the surface. Always clean spills and water off with a clean dry cloth or paper towel.

LONG TERM MAINTENANCE

Avoid the use of scourers or bleaches. Use a humidifier. Use a hygrometer. Always move it with care.

SHIPPING

Flat pack.

DIMENSIONS

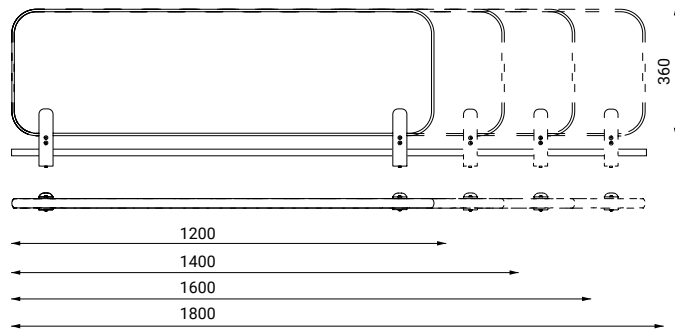

SCREEN STRUCTURE / BASE TYPE

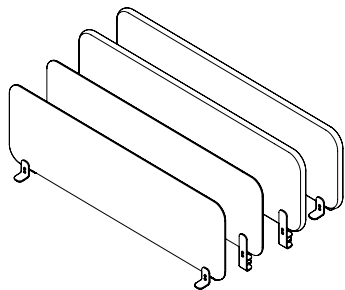

Structure	Chipboard / Acoustic PET Felt / Thermoformed Acoustic PET Felt
Base type	Free standing feet / Desk clamp

MATERIALS

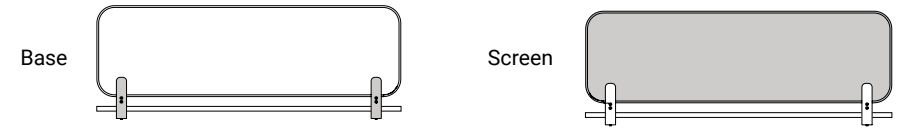

BASE / ACCESORIES COLOURS

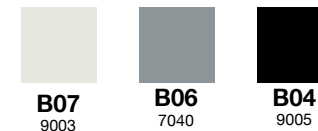

SCREEN COLOURS

- Polyester**
- Class A - Torino | A01 (9201)
 - Class A - Torino | A02 (9203)
 - Class A - Torino | A03 (9306)
 - Class A - Torino | A04 (9406)
 - Class A - Torino | A05 (9501)
 - Class A - Torino | A06 (9602)
 - Class A - Torino | A07 (9616)
 - Class A - Torino | A08 (9702)
 - Class A - Torino | A09 (9706)
 - Class A - Torino | A10 (9717)
 - Class A - Torino | A11 (9801)

- Polyester**
- Class A - Jet | A12 (1106)
 - Class A - Jet | A13 (3036)
 - Class A - Jet | A14 (4027)
 - Class A - Jet | A15 (6007)
 - Class A - Jet | A16 (6013)
 - Class A - Jet | A17 (6014)
 - Class A - Jet | A18 (7025)
 - Class A - Jet | A19 (7041)
 - Class A - Jet | A20 (8009)
 - Class A - Jet | A21 (9304)
 - Class A - Jet | A22 (9281)
 - Class A - Jet | A23 (9804)

- Polyester**
- Class A - One | A24 (1006)
 - Class A - One | A25 (3007)
 - Class A - One | A26 (4030)
 - Class A - One | A27 (4037)
 - Class A - One | A28 (4067)
 - Class A - One | A29 (4028)
 - Class A - One | A30 (8532)
 - Class A - One | A31 (7521)
 - Class A - One | A32 (7026)
 - Class A - One | A33 (6091)

- Wool**
- Class C - Lanee Melange | C01 (WM101)
 - Class C - Lanee Melange | C02 (WM103)
 - Class C - Lanee Melange | C03 (WM111)
 - Class C - Lanee Melange | C04 (WM112)
 - Class C - Lanee Melange | C05 (WM120)
 - Class C - Lanee Melange | C06 (WM125)
 - Class C - Lanee Melange | C07 (WM126)
 - Class C - Lanee Melange | C08 (WM132)
 - Class C - Lanee Melange | C09 (WM133)
 - Class C - Lanee Melange | C10 (WM139)
 - Class C - Lanee Melange | C11 (WM140)
 - Class C - Lanee Melange | C12 (WM142)

- Polyester**
- Class C - Aspect | C13 (WM101)
 - Class C - Aspect | C14 (WM103)
 - Class C - Aspect | C15 (WM111)
 - Class C - Aspect | C16 (WM112)
 - Class C - Aspect | C17 (WM120)
 - Class C - Aspect | C18 (WM125)
 - Class C - Aspect | C19 (WM126)
 - Class C - Aspect | C20 (WM132)
 - Class C - Aspect | C21 (WM133)
 - Class C - Aspect | C22 (WM139)

- Polyester**
- Class E - Synergy | E01 (WM101)
 - Class E - Synergy | E02 (WM103)
 - Class E - Synergy | E03 (WM111)
 - Class E - Synergy | E04 (WM112)
 - Class E - Synergy | E05 (WM120)
 - Class E - Synergy | E06 (WM125)
 - Class E - Synergy | E07 (WM126)
 - Class E - Synergy | E08 (WM132)
 - Class E - Synergy | E09 (WM133)
 - Class E - Synergy | E10 (WM139)